

NO.	Description	Material	Q'TY	Finish
16.	Washer	0.5T Iron	1	Nickel Plated
15.	Nut	2.0T Iron	1	Nickel Plated
14.	Insulator	POM	2	Ivory Color
13.	Insulator	Red Vulcanized Fibre	1	Red Color
12.	Bushing	Brass	1	Nickel Plated
11.	Barrel(W/Thread)	PC	1	Black Color
10.	Cover	0.5T Steel	1	Nickel Plated
9.	Housing	POM	1	Black Color
8.	Ring Spring	0.35T Phosphor Bronze	1	Silver Plated
7.	Transfer Terminal	0.3T Brass	1	Silver Plated
6.	Break Terminal	0.35T Phosphor Bronze	1	Silver Plated
5.	Make Terminal	0.2T Phosphor Bronze	1	Silver Plated
4.	Tip Spring	0.35T Phosphor Bronze	1	Silver Plated
3.	Transfer Terminal	0.4T Brass	1	Silver Plated
2.	Break Terminal	0.35T Phosphor Bronze	1	Silver Plated
1.	Make Terminal	0.2T Phosphor Bronze	1	Silver Plated

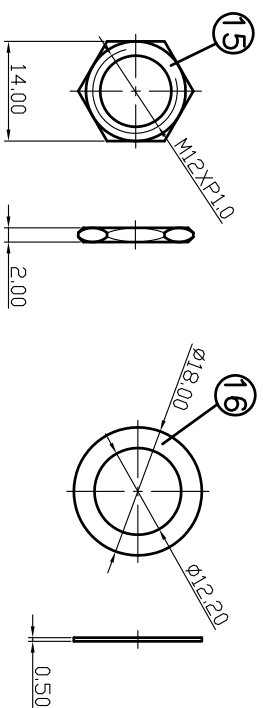
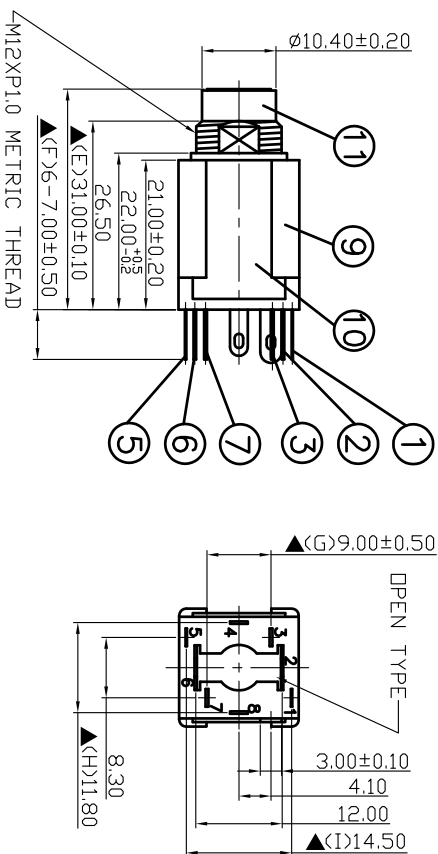
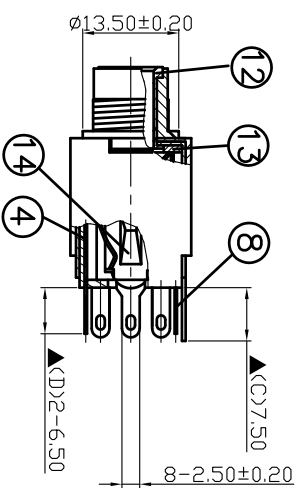

大廣有限公司 DAKOANG CO., LTD.

DATE	DWN	CHKD	APVD	MANAGER
10.12.2011				

PART NAME : 6.3Ø PHONE JACK PART NUMBER: DK1796 SERIES

VERSION:5.0

TOLERANCE :±0.3mm UNLESS OTHERWISE SPECIFIED

UNIT:mm



SCALE:1/1

SPECIFICATIONS:
 Contact Resistance : 30mΩ max
 Insulation Resistance : 100MΩ min. at DC 500V
 Dielectric Withstanding Voltage: AC 500V for one minute
 Remark: ▲ : The Most Important Dimension

Rohs Compliant For Reference 健供參考