

# 5108 Mercury switch

## New product introduction

5108 Sealed type sensor can produce continuous on-off contact closures when in motion. Small size and can be installed in a little space. Can be activated under low current and voltage.

Glass tube has undergone special treatment and will not broken easily.

## Application

Game machines and toys, Security systems, Electrical and electronic products, Personal security alarms, Vibration sensors, Car

## Technical Specification

1. Maximum Switch Rating : 200mA
2. Electrical Life : 200,000 cycles Min.
3. Contact Resistance : 0.2Ω Max.  
(Measured at 45° tilt )
4. Differential Angle : 5° Max.
5. Solder Temperature : Manual soldering 350°C, 3~5 seconds.
6. Operating Temperature : -25°C~100°C

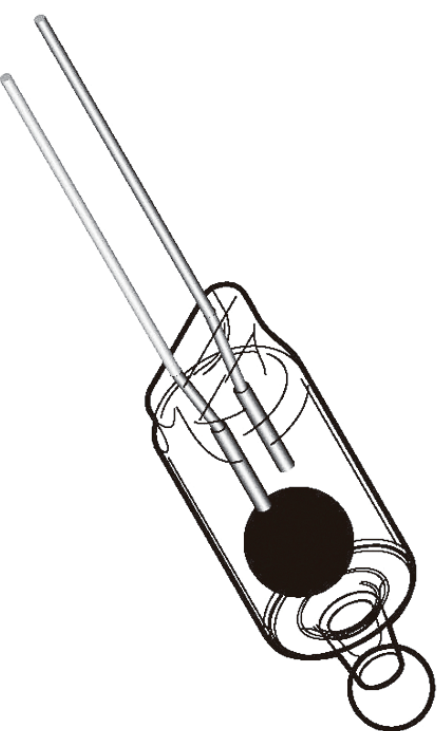
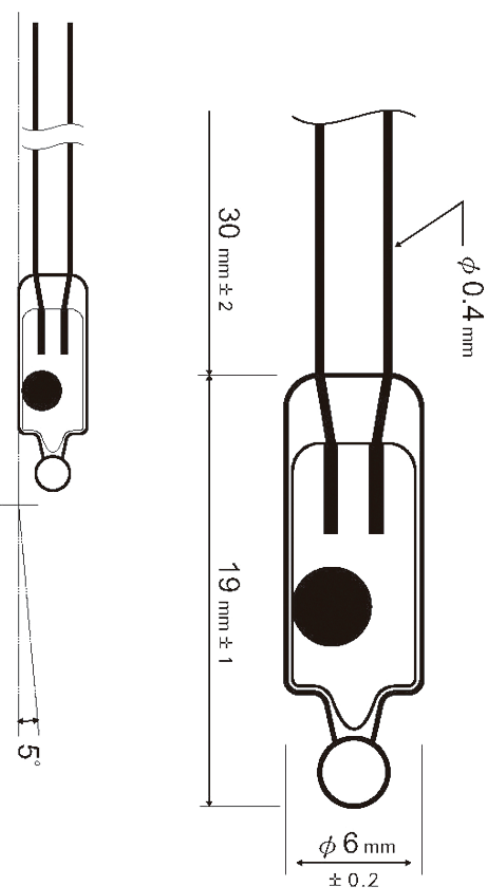

PART NO.		大廣有限公司 DA KOANG CO., LTD.			
DWG NO.		DRAWING	AUDITING	PAGE	1
SERIES NO.	5108	SCALE	3:1	DATE	
DWG. NAME					