

- 1. Electrical rating: 1A 125V AC / 0.5A 250V AC
- 2. Circuit: 2P (SPST)
- 3. Function: PUSH ON-OFF
- 4. Contact Resistance: 2.5V DC 10mΩ or less
- 5. Insulation Resistance: 500V DC 100MΩ or More
- 6. Voltage Breakdown: 1000V AC 1min
- 7. Electrical life: 10000 cycles
- 8. Temperature rise at the terminal: Max. 30°C
- 9. Solder ability of terminal: Max. 300°C 3 Sec
- 10. Mtg. Hole Dial mm: 10 $\varnothing$  mm

|              |
|--------------|
| Button Color |
| Black        |
| White        |
| Red          |

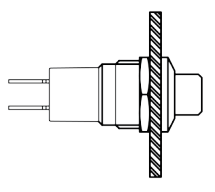

Installation

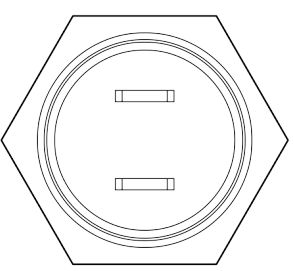
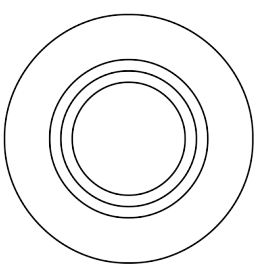
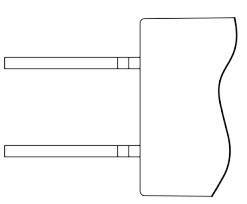
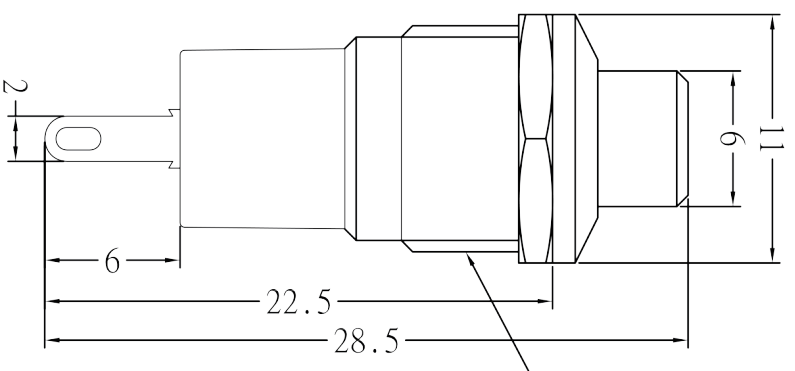
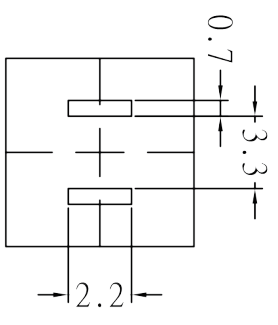
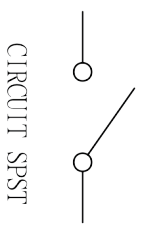

|           |           |
|-----------|-----------|
| 50041     |           |
| SCALE     | 3:1       |
| DWG. BY   | H. R. S.  |
| CHK. BY   | DATE      |
| 2009-8-10 |           |
| DWG. NO.  | F-001-D01 |

大廣有限公司 DA KOANG CO., LTD. PAGE 1/1