

大 廣 有 限 公 司 DA KOANG CO., LTD.

MODEL: 51212

S/O No: OSM21025

1、Outline Drawing:

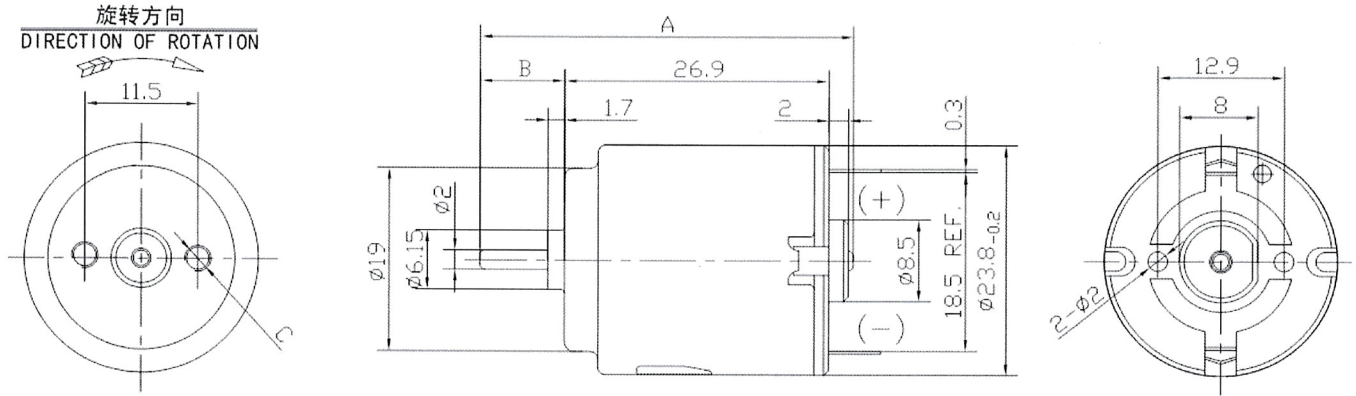

单位: mm

A=38.0 B=7.8±0.5 C=2-Φ2.3

2、Electrical Specification:

VOLTAGE		NO LOAD		AT MAXIMUM EFFICIENCY						STALL		
OPERATING RANGE	NOMINAL	SPEED	CURRENT	SPEED	CURRENT	TORQUE		OUTPUT	EFF	CURRENT	TORQUE	
		rpm	A	rpm	A	mN.m	g.cm	W	%	A	mN.m	g.cm
3.0~7.5	6.0 V CONSTANT	26400	0.356	22499	2.05	2.61	26.60	6.14	49.8	11.850	17.64	180
GENERAL TEST TOLERANCE		±12%	≤0.42	±12%	2.47 MAX	2.35 MIN	23.94 MIN	5.22 MIN	42.3 MIN	10.07 MIN	14.99 MIN	153 MIN

3、Performance Curves:

MODEL: RE260SRA-2860-38 DC=6.0V

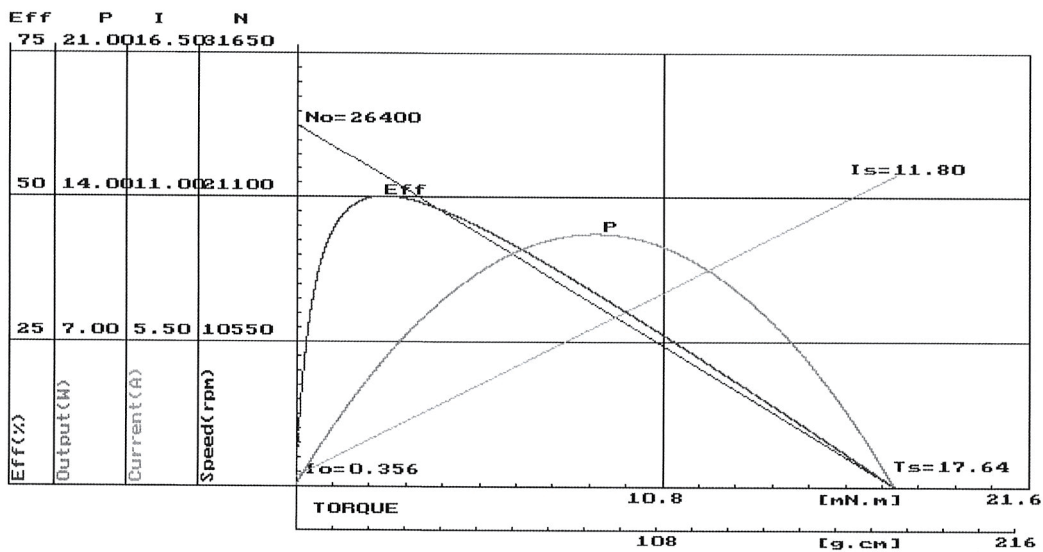

Prepared: ZJQ

Approved:

Date: 2021/06/15