

REV.	ECN NO	DESCRIPTION	REVISED	DATE
A1	---	新订图面	LBD	2010.05.10

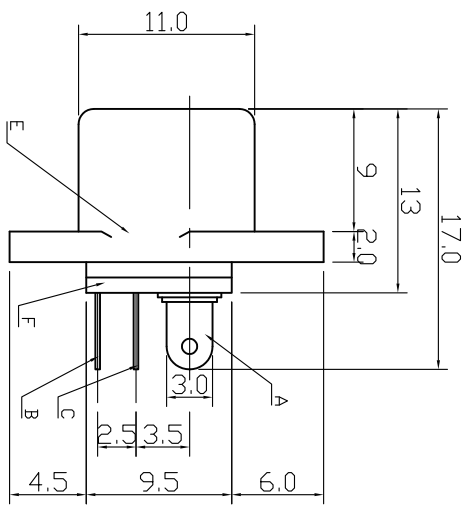

SPECIFICATION
 1.Rating : DC 50V 1.5A;
 2.Contact resistance: $\leq 30m\Omega$;
 3.Insulation resistance: $\geq 100M\Omega$ (DC500V);
 4.Withstand voltage: 500VAC ;
 5.Insertion and extraction force: 5-30N;
 6.life test: 5,000 cycles;

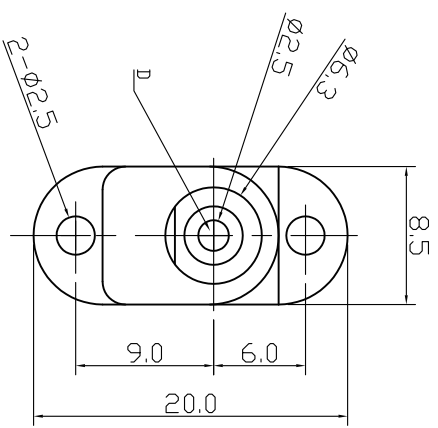
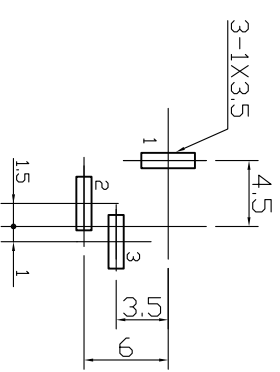
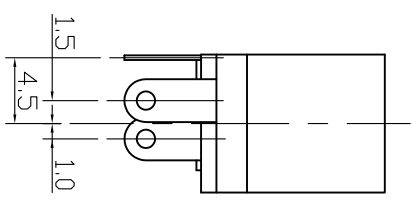

Recommend PCB layout
 (Jack TOP View)
 Tolerances: ± 0.05
 Recommend PCB Thickness: 1.6mm

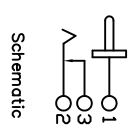

Schematic

NO.	PART NAME	Q'TY	PART NUMBER	MATERIAL	PLATING & COCLR	Remark
F	Cover Board	1	DC-007-202	ABS	Black	
E	House	1	DC-007-201	ABS	Black	
D	Mandril	1	DC-007-104	H59	CuSn	
C	3# Pin	1	DC-007-103	H62 T=0.3mm	CuSn	
B	Reed	1	DC-007-102	Mn65 T=0.25mm	鍍錳	
A	1# Pin	1	DC-007-101	H62 T=0.3mm	CuSn	

UNLESS OTHERWISE SPECIFIED TOLERANCES		DECIMALS:		ANGLES:	
X	± 0.5	X	$\pm 2^\circ$	X	$\pm 1^\circ$
X.X	± 0.4	X.X	± 0.4	X.X	$\pm 1^\circ$
X.XX	± 0.3	X.XX	± 0.3	X.XX	$\pm 1^\circ$

大廣有限公司 DA KOANG CO., LTD.					
TITLE:	2054A				
SCALE:ND	UNIT: mm	PROJECTION:	Φ	P/N	DC-007
SIZE: A3	PAGE:1	DF: 1	REV: A1	DWG:ND:	DC-007
APPROVED BY:	CHECKED BY:				PREPARED BY:
YSG	ZY				LBD
CUSTOMER COPY					