

REVISONS	
ISS SYMBOL	DESCRIPTION \ DATE
A2	變更 C RING 和 FERRULE 的規格 \ 09/19/05'

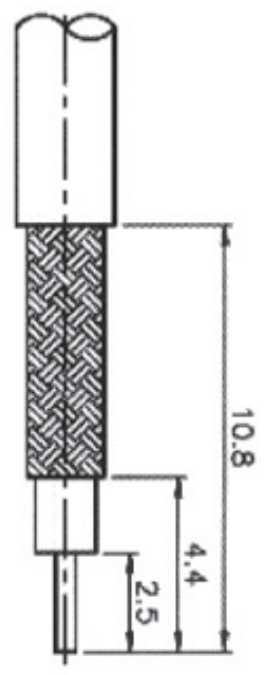

RECOMMENDED  
CABLE STRIPPING DIM'S  
(建議剝線尺寸)

REMARK: RoHS REQUIREMENT APPLIED  
(符合 RoHS)

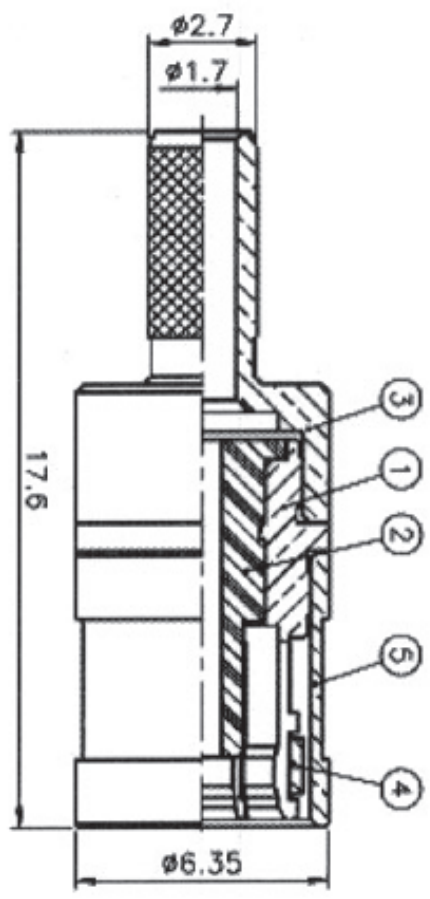
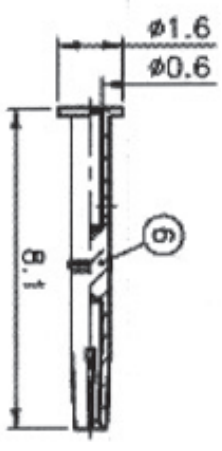
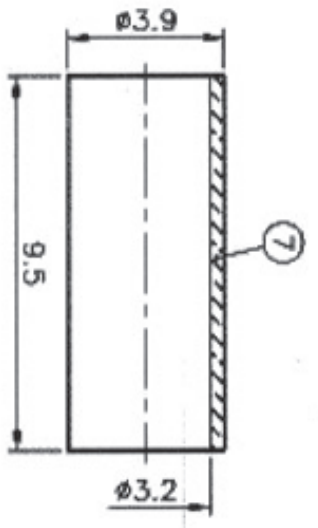

NOTES: FINISH (PLATING THICKNESS IN MICRO-INCHES)  
 1. BRASS PER QQ-B-626  
 2. GOLD PL. 3 MIN OVER NICKEL PL. 70 MIN THICK OVER COPPER STRIKE  
 3. GOLD PL. 30 MIN OVER NICKEL PL. 70 MIN THICK OVER COPPER STRIKE  
 4. TEFLON MIL-P-19468  
 5. BERYLLIUM COPPER PER QQ-C-530  
 6. BRASS JIS H 3250, C 2700

1. CRIMPED FERRULE  
HEX CRIMP SIZE .128"  
(鍍金壓線工具)  
2. CONTACT PIN TO SOLDER  
(中心針焊接)

7	FERRULE	NOTE 6	NOTE 2	1	CO6-079GA01	DIMENSIONS ARE IN MILLIMETERS UNLESS OTHERWISE SPECIFIED TOLERANCES (公差) 0.5~6 = ±0.2 >6~30 = ±0.4 >30~120 = ±0.6 >120~315 = ±1 >315~1000 = ±1.6 ANGLES(角度) = ±5°	PART NO.	APPROVED DATE 09/19/05'	大廣有限公司 DA KOANG CO., LTD.
6	CONTACT PIN	NOTE 5	NOTE 3	1	CO1-179GE02				
5	SHELL	NOTE 1	NOTE 2						
4	C RING	NOTE 5	NONE						
3	BRAID HOLDER	NOTE 1	NOTE 2	1	H9101-BGTGD01				
2	INSULATOR	NOTE 4	WHITE						
1	BODY	NOTE 1	NOTE 2						
NO. DESCRIPTION MATERIAL FINISH QTY DRAWING NO. SCALE 5/1 ISSUE A2						CHECKED DATE 09/19/05'	TITLE SMB CRIMP PLUG (FOR RG-174/U, 188A/U, 316/U)	DRAWN DATE 09/19/05'	FILE NO. Z:\BOM\B9\B9101BGTGD01-A2R